

# FOAM SOAP DISPENSER PP 103



80 x 298 x 120 mm

400 ml foam soap concentrate

- Full metal housing in robust, easy-to-clean stainless steel AISI 316L, satin finished, rounded vertical corners.
- Designed for 400 ml disposable bottle of foam soap concentrate.
- Inspection slot to indicate refill level.
- Housing swings down for refilling.
- Dispenser with drip-free, single-hand pull-operation soap pump.
- Dispenser lockable with cylinder lock, fitted on the top.
- Easy to clean due to optimum accessibility.
- Simple mounting: line up with tiles and fasten with 4 screws.

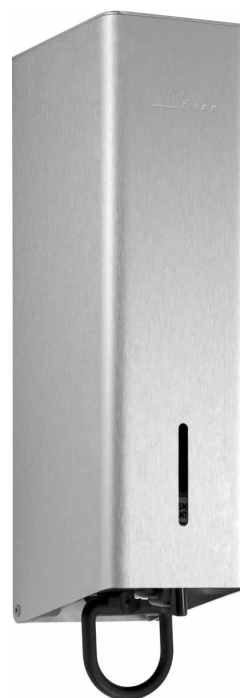

## Suggested text for specifications:

Foam soap dispenser in stainless steel AISI 316L for surface mounting, satin finished, lockable with cylinder lock, rounded vertical corners.

Dimensions 80 x 298 x 120 mm; for 400 ml disposable bottles; includes mounting components and first fill.

Article No. PP 103

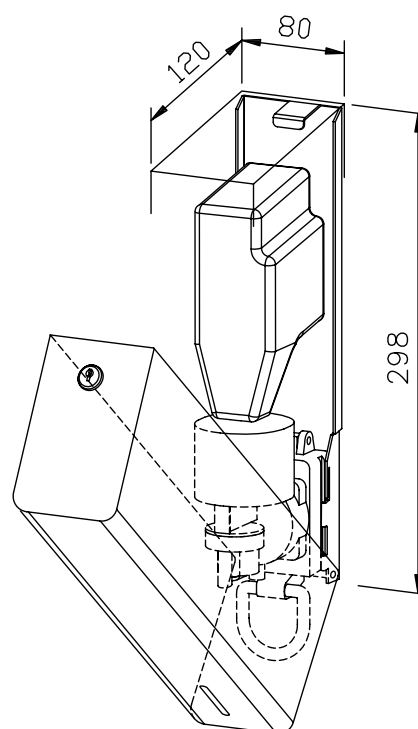

Available surfaces	Ident-No.
satin finished (standard)	727 338
highly polished	731 338
(coloured) plastic powder - coating	728 338

## Ernst Wagner GmbH & Co. KG

Ernst-Abbe-Straße 21 · D-72770 Reutlingen · Tel.: +49712151539-0 · Fax: -20  
info@wagner-ewar.de · www.wagner-ewar.de

WAGNER  
EWAR